

Operational manual

Praktika QL-04(K) turnstile

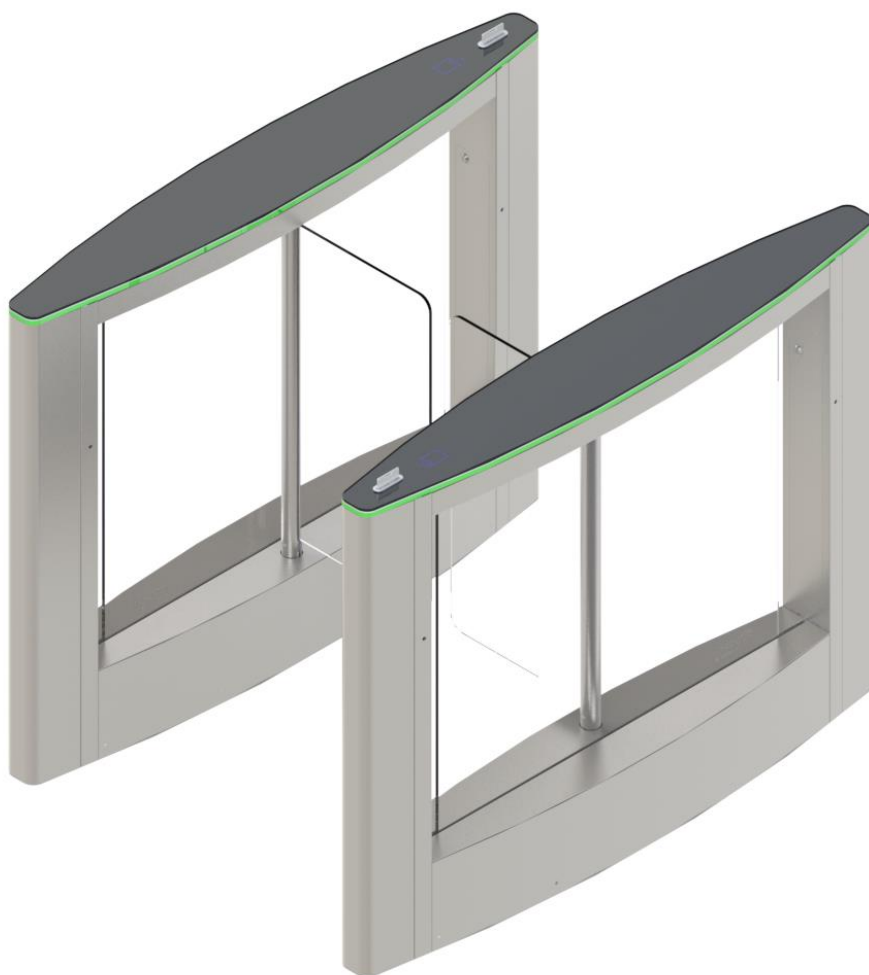

CONTENTS

List of abbreviations used	4
2. Delivery set.....	4
3. Basic specifications	6
4. Product design	7
5. Transportation and storage	10
6. Safety requirements.....	11
7. Description of card collector	Ошибка! Закладка не определена.
7.1. Card collector purpose	13
7.2. Product design	13
7.3. Removing guest cards from card collector	14
8. Speedgate operation	14
8.1. Turning on	14
8.2. Operating modes	15
8.3. Turnstile operation with control board.....	15
Manual alarm unlock mode.....	16
8.4. Adjustment of remote control panel	17
8.5. Control with card collector	18
Appendix 1. Recommended power supplies.....	20
Appendix 2. Troubleshooting for speedgate	21

List of abbreviations used

PS	– power supply
FA	– fire alarm
CB	– control board
ACS	– access control system
OD	– operating device

Speedgate firmware version FW v2.4

Card collector firmware version FWv1.52

1. Product purpose

Praktika-QL-04(K) turnstile is designed for access control and pedestrian flow management. The speedgate can be used at checkpoints at factories and organizations, institutions, banks, schools, sports and entertainment facilities, shops, railway stations, etc.

To ensure easy and quick passage of people it is recommended to install one speedgate for every 500 people working in one shift.

2. Delivery set

Table 1. Delivery set

Item	Qty, pcs.
Praktika QL-04(K)	1
Remote control panel with cable	1
Hatch lock key	8
Datasheet	1
Installation guidelines	1
Operational manual	1.
SORMAT PFG ES 10* anchor	6
M10x60 DIN933 hexagon screw *	6
Connecting cable PVA 2x1,5*	2
Units arrangement diagram *	1

*-supplied optionally

3. Basic specifications

Table 2 Basic specifications

Description	Speedgate	RC panel
Overall dimensions of a side unit (HxWxD) with a swing opened, mm	1052x1330x208	107x107x25
Overall dimensions of two-sided unit (HxWxD) with swings opened, mm	1052x1330x208	107x107x25
Overall dimensions of a side unit (HxWxD), mm	1052x1330x510	107x107x25
Overall dimensions of two-sided unit (HxWxD), mm	1052x1330x812	107x107x25
Weight of side unit, kg	110,0	0,5
Weight of two-sided unit, kg	130,0	0,5
Temperature range, °C - operation - transportation and storage	+1...+40 +1...+40	+1...+40 +1...+40
Atmosphere relative humidity, no more than %	80	80
Throughput, people per minute	30	
Card collector capacity (pcs.) **	50	
Max. number of connected control boards, pcs	2	
Lifetime, years	8	8

Table 2. Electrical specifications

Specifications	Speedgate	Card collector**	Control board
Supply voltage, V: - nominal - working	12,0 10,8...15,0	12,0 8...18,0	12,0 7,5...15,0
Average current in standby mode * A	0,7	0,2	
Average current in passage mode * A	5,0		
Maximal current of a side unit*/***, A	7,5		
Maximal current of card collector*, A		1,5	

*- values mentioned at a nominal supply voltage

** - optionally supplied

*** - side units required to form a passage area, i.e. 2 power supplies units 12V 5A

The manufacturer reserves the right to change the packaging, technical specifications and appearance without notice.

4. Product design

Speedgate housing

Speedgate housing is made of brushed stainless steel, wings are made of tempered glass. Additionally the card collector can be integrated in the design of the speedgate. Base covers for access to PU, Control board and ACS cables holes (Fig. 1) are provided at the bottom of side units

LED strip indicates turnstile mode of passage set at the moment. Indication strip is covered with tempered glass.

With the help of one-sided and two-sided units, it's possible to organize unlimited number of passages depending on customer's needs.

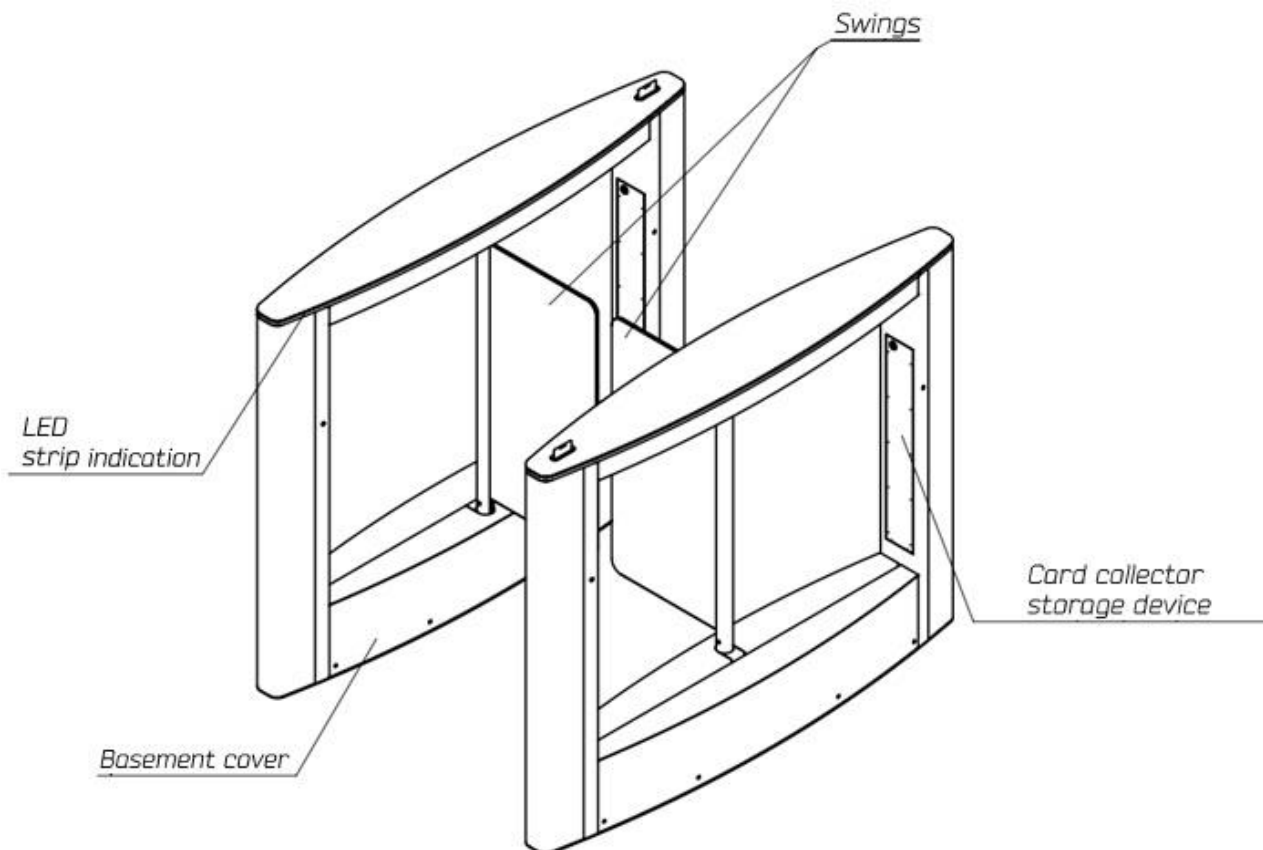

Fig.1 General view of speedgate

LED indication strip

Speedgate indication strip is made of diodes covered with light-diffusing insertion. Speedgate operating modes are reflected by moving diodes on the indication strip (Fig 2).

Inserted into the indication strip diodes are covered with tempered glass. LED strip reflects turnstile mode of passage set at the moment.

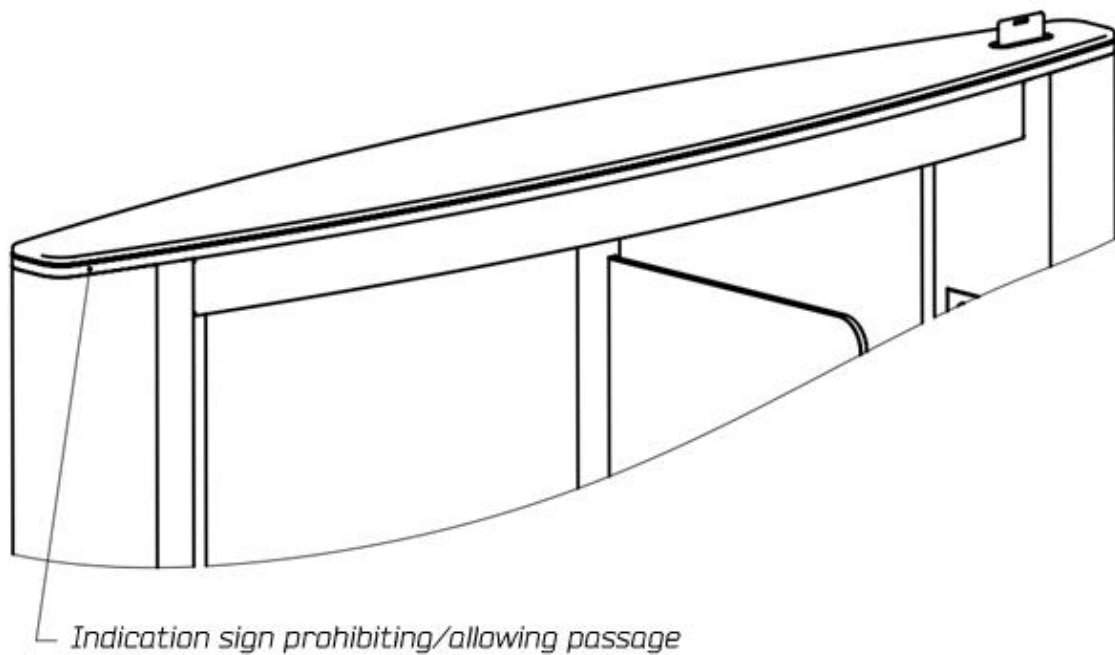

Fig. 2 LED indication strip view

Control board

The housing of CB is made of polished stainless steel. On the front side there are control buttons and LED indicators of CB operational modes (Fig. 3). The standard supplied cable is 5 m long.

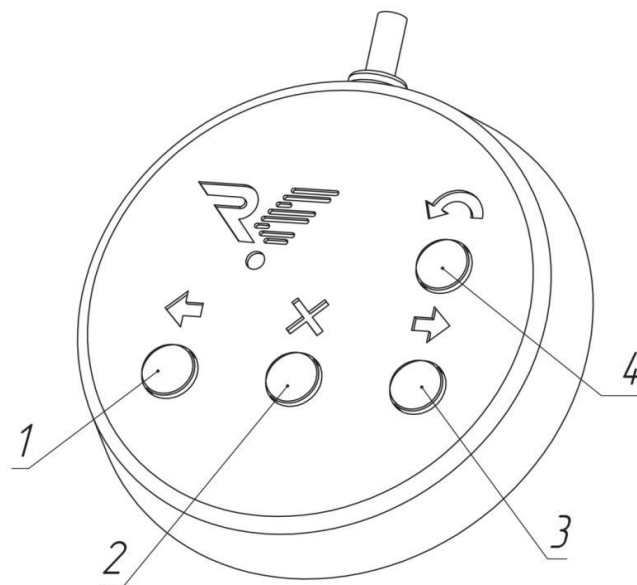

Fig. 4 General view of remote control board

5. Transportation and storage

Speedgate in its original packaging shall be transported by air, by road and by railroad with protection from direct exposure to rain and dust without range limitation. It is allowed to stack boxes in 2 rows during transportation and storage if Euro-pallets used. Keep the speedgate in dry (no moisture condensation) heated places within +1 to + 40 °C temperature range. Avoid vapors of acids, alkalis, and corrosive gases at the storage place. Storage of speedgate in the original package in a dry unheated premises or closed transport containers is permitted for short periods, no more than 3 days. Before startup, the speedgate must be kept in a room with normal climate conditions for 12 hours after storage in unheated rooms.

6. Safety requirements

CAUTION! Failure to comply with the safety requirements specified in this section may result in damage to human life and health, total or partial loss of workability of products and (or) auxiliary equipment.

CAUTION! Specific guidance on the use of the speedgate:

1. The sensors are installed in the stands of speedgate at a height of 820 mm.

Children shorter than 820 mm cannot be identified by the speedgate.

Children must be accompanied by adults in charge when passing through the speedgate!

Baggage, carts, bags etc. cannot be identified by the speedgate.

2. If there is no distance in the passage between the two visitors, they might be identified as one.

CAUTION! Installation of speedgate must be carried out by qualified personnel according to the instructions.

CAUTION! The producer disclaims any liability for damage to human life and health, total or partial loss of workability of products and (or) auxiliary equipment for non-compliance of the safety requirements specified in this section, as well as terminate the product warranty.

IT IS NOT ALLOWED TO:

- Set the power supply inside the speedgate housing as this might lead to electric shock to persons;
- Set the speedgate other than in dry and heated places;
- Impede or accelerate the speedgate wings;
- Apply chemically aggressive cleaning detergents (as pastes and liquids) to the materials of the housing.

7. Description of card collector

7.1. Card collector purpose

Card collector (Fig. 4) is designed for collection and storage of proximity access cards at the exit from the facility. Flexible logic of the controller allows the integration of the card reader with any access control systems.

7.2. Product design

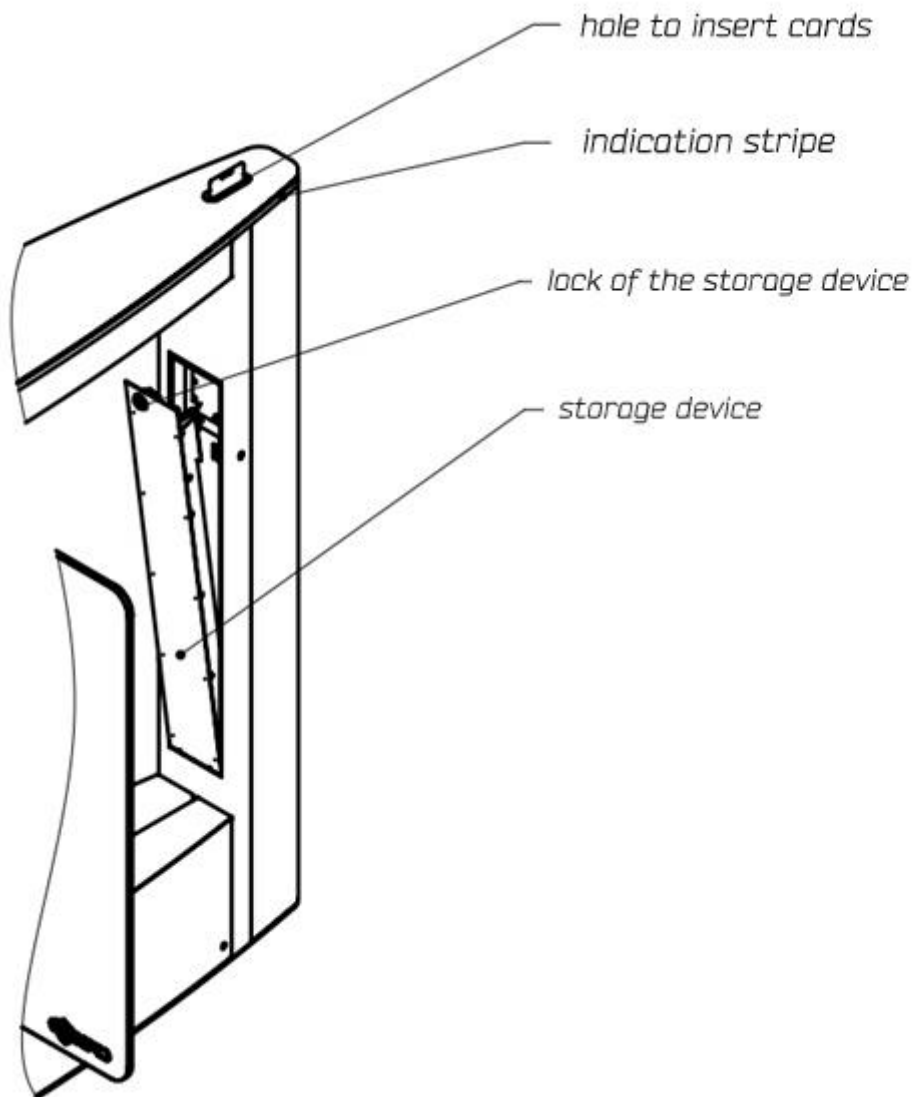

Fig.4 General view of the card collector

In the back of the housing there is a storage device for card collector for quick access to collected cards. The hatch has card storage device where 50 cards can be stored.

ATTENTION(!) Reader is included in the delivery set of card collector. Two types of readers can be installed: PROX13 и PROX125. Customer can choose reader model suitable for the existing system.

7.3. Removing guest cards from card collector

7.3.1. Open the hatch lock of card collector with a key (Fig. 4).

7.3.2. Put a bag to collect cards (not supplied) underneath storage device.

7.3.3. Lift the storage shutter to remove cards.

7.3.4. Lower the storage shutter and close the hatch with a key.

8. Speedgate operation

8.1. Turning on

Connect power supply units to 220V power network and turn them on. Wings of speedgate will move to the starting closed position, LED indication stripes fromn inside and outside will turn blue. Readers of permanent cards (located on the upper panel) will be lightened with red color, it means that readers are ready to identify the card. LED indicator of

button 2 on the RC panel will turn red (Fig. 3). The speedgate is ready for operation.

8.2. Operating modes

The speedgate has several modes of operation. The desired mode is set by using RC panel or proximity cards. Operational modes are displayed on the panel in the form of mnemonic signs depicting authorization and non-authorization of passage.

8.3. Control with remote control board

General view of the RC panel is shown in Fig. 3. Each button is equipped with the LED indicator displaying operation of the speedgate.

"Stop" mode

Режим «Стоп» устанавливается при включении турникета. Створки турникета закрыты. Переход из другого режима в режим «Стоп» осуществляется с помощью кнопки 2, при этом над кнопкой 2 светодиодный индикатор загорается красным.

"Stop" mode is set when the speedgate is turned on. Wings are closed. Switch from another mode to "Stop" is performed by pressing button 2, in this case LED indicator above button 2 turns red. In this mode the passage is non-authorized in both directions.

Both stripes: the inner and outer ones will be of blue color, permanent card readers (located on the upper panel) will be red.

Single passage mode

Button 1 (3) turns on single passage mode to the left (right). This mode allows one pass to the left (right) with a subsequent changing to "Stop" mode. Green arrow indicator turns on on the display showing a free passage to the left (right). Green LED indicator on the RC panel turns on above the button corresponding to the authorized passage and a red indicator - above button 2. If the passage is not performed within 5 seconds, the speedgate switches to "Stop" automatically.

Free passage mode

In order to switch to this mode press and hold button 1, then press button 3 and release both buttons. In this mode an unlimited number of passages is allowed in both directions. Arrows turn on in both directions. Green LED indicators on the RC panel LED turn on above the button 1 and 3.

"Antipanic" mode

This mode is turned on by pressing button 4 while in any other mode. In this mode the speedgate will open wings towards exit direction. Green indicator on the RC panel will turn on button 4.

Manual alarm unlock mode

The speedgate has manual disblock of the swings in case of power loss. In order to disblock them it's necessary to (fig.5):

1. Remove the storage device from the inner turnstile stand.
2. Press a leverage with a finger through a hole located on the lower part of the turnstile's stand, making draft of speedgate disblock moving.

3. Move the swing manually.

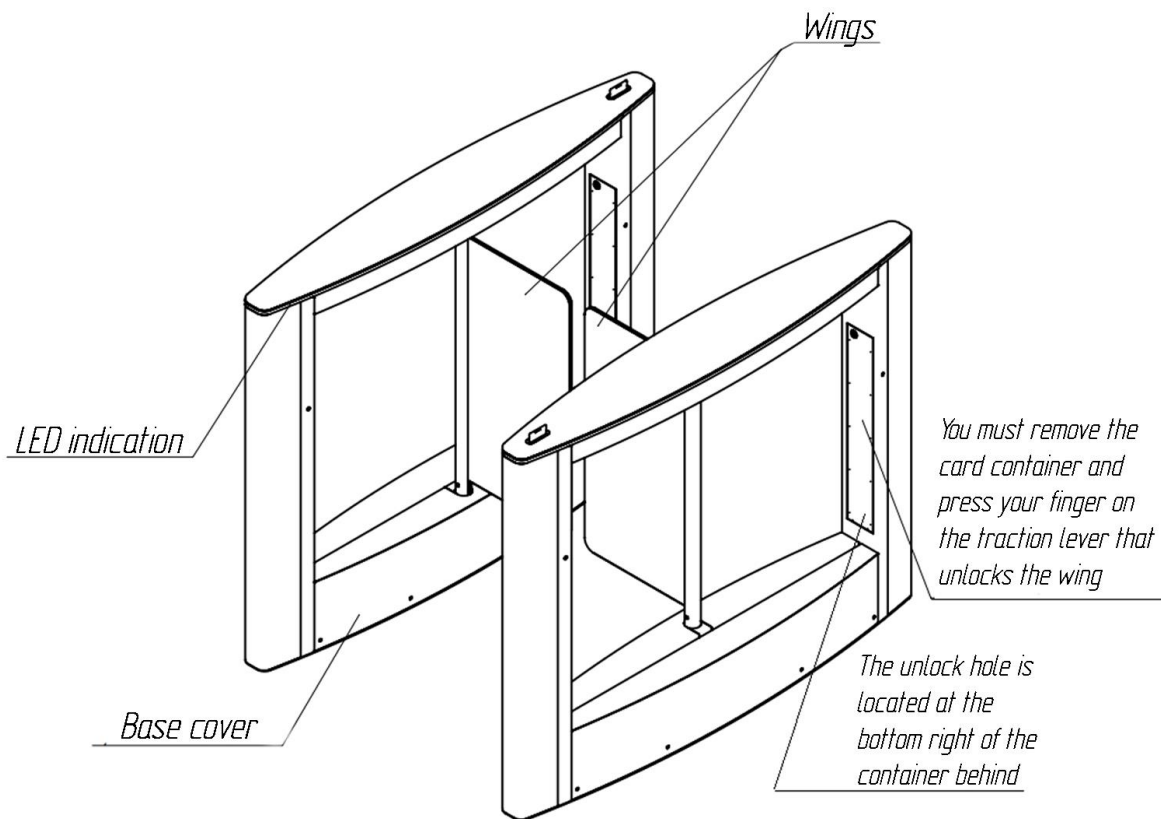

Fig.5 Manual disblock

8.4. Adjustment of remote control panel

Speedgate can be set in various directions in relation to the user. In some cases it is needed to reverse left / right passage buttons. This can be done by the following operations:

- Power off the speedgate;
- Press and hold left (1) and right (3) buttons;
- Turn on the speedgate;
- Press button 2 while still holding buttons 1 and 3;
- Release buttons 1 and 3;
- Release button 2.

Now when you click left button passage will be allowed to the right and vice versa. The current functions of the buttons are saved and do not reset when power is turned off. In order to return to the initial modification re-do the above sequence.

8.5. Control with card collector

8.5. Control with card collector

The card collector is set in the standby mode after power-up. It is necessary to present access card to switch the mode.

Passage with permanent cards

When an authorized permanent visitor card is presented to the reader card collector unlocks the speedgate for the time specified by ACS controller (depending on the operating mode; for 5 seconds in pulse mode). During the specified time interval other cards are not accepted. When the passage is performed or the specified time interval is expired card collector switches into standby mode and can collect the next card. Green arrow turns on on the LED panel, indicating the authorization of the passage.

Passage with guest cards

Guest card shall be inserted into the card hole up to the stop otherwise it will be ignored. In case the presented card is authorized, the card collector collects it and then unlocks OD for 5 seconds.

Storage device is full

When the storage device is overfilled, the card collector stops collecting guest cards and provides four short audio signals at intervals of 4 sec., the LED panel flashes red cross indicator at an interval of 4 seconds. Audio signal lasts for 3 minutes; then red cross on LED display continues single blinks 1 time in 2 sec. Passages with permanent cards are performed normally. In order to switch the card collector in the standard operating mode, remove cards from the storage device (see. Article 7.3).

Emergency mode

During the operation of the card collector there might be a situation when a card or a foreign object becomes jammed by shutter of the card collector. To resolve such situations is an emergency mode.

- Open the hatch of the card collector using the key (Fig. 4);
- Press and hold BUT1 button on the board of the card collector (Fig. 5). When the button is pressed shutter is open forcedly and a continuous audio signal is performed;
- Remove the object that impedes the normal operation of the system;
- Release BUT1 button and close the hatch with a key.

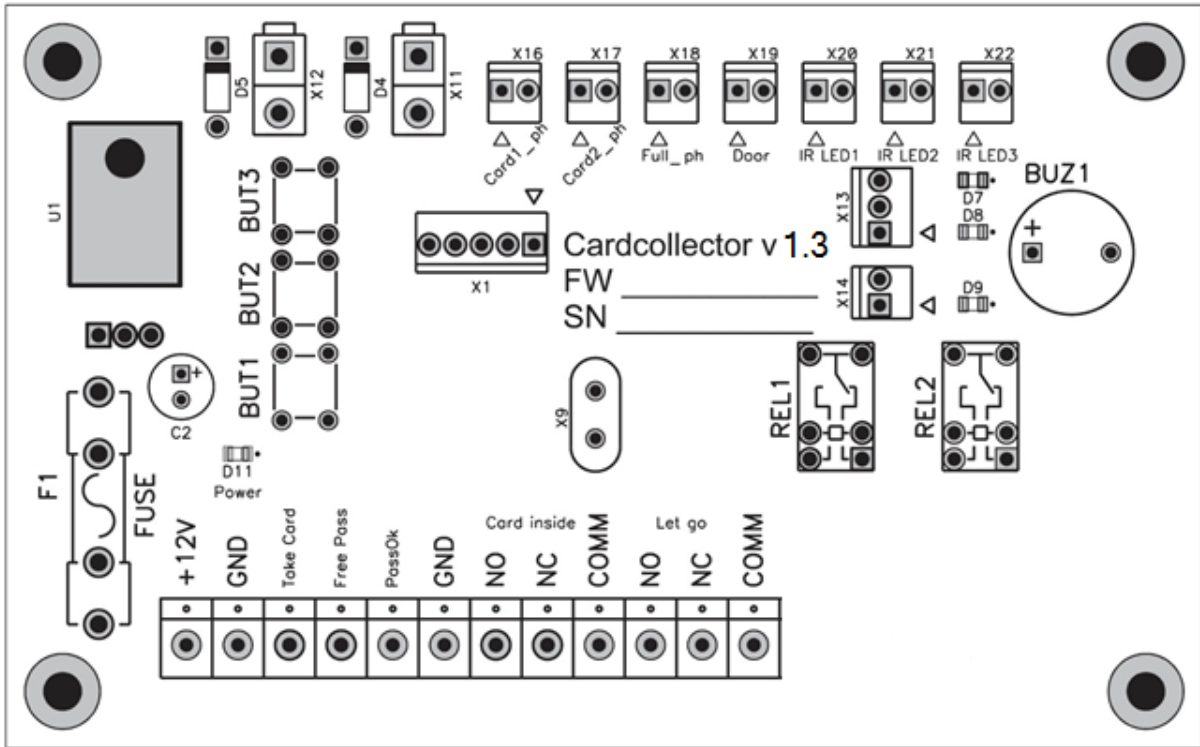

Fig. 6. General view of board

Appendix 1. Recommended power supplies

1. MEAN WELL DR-120-12
2. MEAN WELL EDR-120-12

Appendix 2. Troubleshooting for speedgate

Table 1. Troubleshooting for the speedgate

Fault	Remedy
PS unit is connected, but the speedgate does not work	Check the connection cable; Check the fuses on motherboard
RC panel does not work	Check the RC panel connection; If +12 and GND contacts are connected properly try to interchange positions of CL and CH;

PRODUCT IS CERTIFIED

Voltage: 12V DC

Current: 5A

Importer: VZR System OU

Tulika 19, Tallinn 10613

+ 372 5844 4957

e-mail:

info@vzrsystem.ee

www.vzrsystem.ee

Manufacturer:

«Vozrozhdenie»

66, Sofiyskaya str. 192289

St. Petersburg, Russia

Tel. 8(812)706-95-31

e-mail: sales@oxgard.com

www.oxgard.com



ISO 9001:2008



ООО "Возрождение"
192289 Санкт-Петербург
ул. Софийская, д.66
тел./факс +7 (812) 336 15 94
www.oxgard.com
info@oxgard.com